

# SR1-X/SR1-P

● Robot controller with advanced functions

Compact design with high performance. Although with one axis, functions of upper class controllers.



Main functions ▶ P.035

## Features

### 1 Support most operating method

Supports diverse operating methods including program operation, point trace, and movement to specified coordinates, etc.

### 2 Position data hold time: 1 year

The absolute position data hold time which was only 2 weeks, has now been drastically increased to about 1 year.

### 3 I/O assignment Change

Changing the I/O assignment allows selecting operations such as program operation, point trace, point teaching, and trace operation by specifying coordinates. Jog operation can also be performed from the upstream device.

### 4 Use of two power supplies

Isolating into main power supply and control power supply yields an even higher degree of safety. It also makes servicing easier when an alarm occurs.

### 5 Current position output function

These controllers can output the current position as feedback pulse or binary data. This allows the upstream device to know the robot position in real-time.

### 6 Torque limiting

This function limits the maximum torque value to an optional timing. These controllers offer 2 types of torque limiting: limiting the torque by using parameter data, and limiting torque by using analog input voltages.

### 7 Various monitor functions

Offers monitor functions of different types including input/output status monitoring, duty monitoring, and analog monitoring, etc.

## Model Overview

Name	SR1-X	SR1-P
Power	05 / 10 driver Single phase 100 to 115V/200 to 230V +/-10% maximum (50/60Hz)	20 driver Single phase 200 to 230V +/-10% maximum (50/60Hz)
Operating method	Programming / I/O point tracing / Remote command / Operation using RS-232C communication	
Maximum number of controllable axes	Single-axis	
Position detection method	Absolute / Incremental	Incremental / Semi-absolute
Controllable robot	Single-axis robot FLIP-X	Linear motor single-axis robot PHASER
Programming box	HPB / HPB-D (with enable switch) <b>P.393</b>	
Support software for PC	POPCOM <b>P.391</b>	

## Ordering method

### ● SR1-X

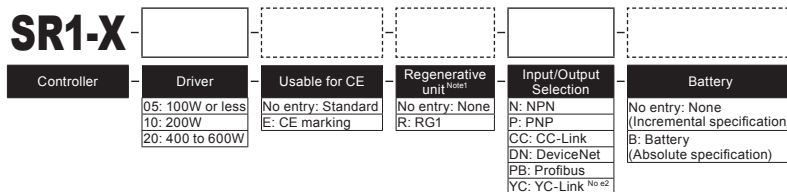

Note 1. Driver selection and regenerative unit selection depends on the robot type. See the selection table on the next page for selecting the driver/regenerative circuit.  
Note 2. Available only for the slave.

### ● SR1-P

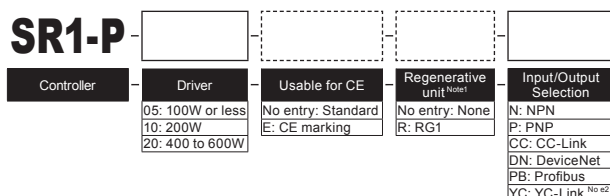

Note 1. Driver selection and regenerative unit selection depends on the robot type. See the selection table on the next page for selecting the driver/regenerative circuit.  
Note 2. Available only for the slave.

APPLICATION  
TRANSERVO  
Compact single-axis robots  
FLIP-X  
Single-axis robots  
PHASER  
Linear motor single-axis robots  
XY-X  
Cartesian robots  
YK-XG  
SCARA robots  
YP-X  
Pick & place robots  
CLEAN  
CONTROLLER  
INFORMATION  
Robot positioner  
Pulse string driver  
Robot controller  
IVY  
Option

# SR1-X/SR1-P

APPLICATION  
TRANSMISSION  
FLIP-X  
PHASER  
XY-X  
YK-XG  
YP-X  
CLEAN  
CONTROLLER INFORMATION  
Robot positioner  
Pulse string driver  
Robot controller  
I/VY  
Option

## Driver / regenerative unit selection table

### SR1-X

		FLIP-X																							
		T4H/C4H	T5H/C5H	T6/C6	T9	T9H	F8/C8	F8L/C8L	F8LH/C8LH	F10	F14/C14	F14H/C14H	F17/C17	F17L/C17L	F20/C20	F20N	N15/N15D	N18/N18D	B10	B14	B14H	R5	R10	R20	
Driver selection	SR1-X	05	●	●	●		●	●	●	●	●									●	●	●	●	●	
		10				●						●													●
		20											●	●	●	●	●	●	●						
Regenerative unit	No entry (None)		●	●	●	(1)	(2)	●	●	(1)	(1)	(2)	(3)		(3)	(4)				●	●	(5)	●	●	●
	R (RG1)					(1)	(2)			(1)	(1)	(2)	(3)	●	(3)	(4)	●	●				(5)			

- (1) Regenerative unit is needed if using in a perpendicular position and movement stroke is 700mm or more.
- (2) Regenerative unit is needed if using in a perpendicular position.
- (3) Regenerative unit is needed if using in a perpendicular position, using at maximum speeds exceeding 1000mm per second, or if using high leads (40).
- (4) Regenerative unit is needed if using at maximum speeds exceeding 1000mm per second.
- (5) Regenerative unit is needed if using at maximum speeds exceeding 1250mm per second.

### SR1-P

		PHASER								
		MR12/MR12D	MR16/MR16D	MR16H/MR16HD	MR20/MR20D	MR25/MR25D	MF15/MF15D	MF20/MF20D	MF30/MF30D	MF50/MF50D
Driver selection	SR1-P	05	●	●			●	●	●	
		10			●	●	●			
		20			●			●	●	
Regenerative unit	No entry (None)		●	●	●	●	●			
	R (RG1)						●	●	●	

## SR1-X / SR1-P part names

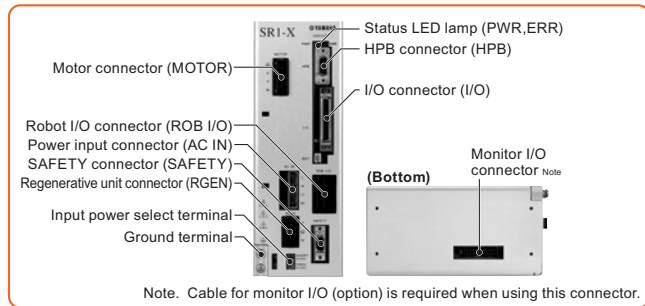

## SR1-X / SR1-P 05 · 10 dimensions

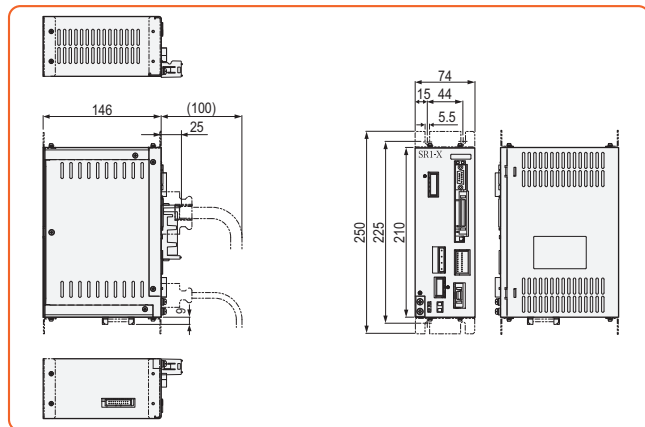

## SR1-X / SR1-P 20 dimensions

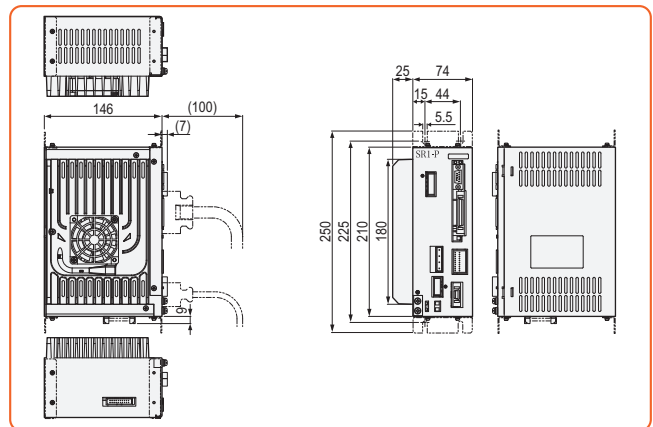

## Regenerative unit RG1

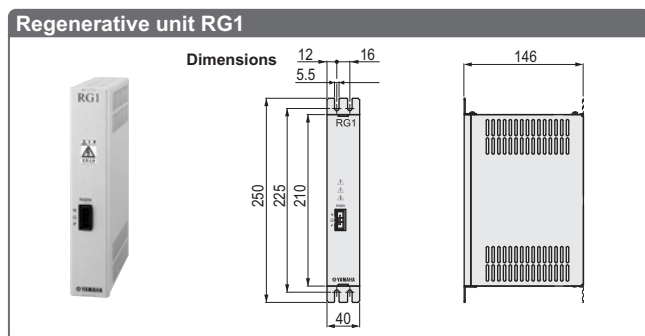

### Basic specifications

Item	RG1
Model	KBG-M4107-0A (Including accessory)
Dimensions	W40 × H210 × D146mm
Weight	0.8kg
Regenerative voltage	Approx. 380V or more
Regenerative stop voltage	Approx. 360V or less
Accessory	Cable for connection with controller (300mm)

Note. Always leave an empty space (gap of about 20mm) between this unit and the adjacent controller. Also, always use the dedicated cable when connecting the controller.

Basic specifications									
Item	Model	SR1-X	SR1-P						
Basic specifications	Driver model	SR1-X-05	SR1-X-10	SR1-X-20	SR1-P-05	SR1-P-10	SR1-P-20		
	Applicable motor output	200V 100W	200V 200W	200V 600W	200V 100W	200V 200W	200V 600W		
	Number of controllable axes	Single-axis							
	Controllable robots	Single-axis robot FLIP-X (exclude T4, T5)			Linear motor single-axis robot PHASER (exclude MF100)				
	Maximum power consumption	400VA	600VA	1400VA	400VA	600VA	1400VA		
	Capacity of the connected motor	100W	200W	600W	100W	200W	600W		
	Dimensions	W74 × H210 × D146mm		W99 × H210 × D146mm	W74 × H210 × D146mm		W99 × H210 × D146mm		
	Weight	1.54kg		1.92kg	1.54kg		1.92kg		
	Input power supply	Control power supply	Single phase AC100 to 115/200V +/-10% maximum					50/60Hz	
		Motor power supply	Single phase AC100 to 115/200V +/-10% maximum 50/60Hz		Single phase AC200 to 230V +/-10% maximum 50/60Hz	Single phase AC100 to 115/200V +/-10% maximum 50/60Hz		Single phase AC200 to 230V +/-10% maximum 50/60Hz	
Axis control	Drive method	AC full-digital software servo							
	Position detection method	Multi-turn resolver with data backup function			Magnetic linear scale				
	Operating method	Programming, I/O point tracing, Remote command, Operation using RS-232C communication							
	Position indication units	mm (millimeters), deg (degrees)							
	Speed setting	1% to 100% (Setting by 1% unit)							
	Acceleration setting	1. Automatic speed setting per robot No. and payload 2. Setting based on acceleration and deceleration parameter (Setting by 1% unit)							
	Resolution	16384 P/rev			1μm				
	Origin search method	Absolute, Incremental			Incremental, Semi-absolute				
Program	Program language	YAMAHA SRC							
	Multitasks	4 tasks maximum							
	Point-data input method	Manual data input (coordinate value input), Direct teaching, Teaching playback							
Memory	Programs	100 programs 255 steps / 1 programs 3000 steps / total							
	Points	1000 points							
External input/output	STD.DIO	I/O input	Dedicated input 8 points, General input 16 points						
		I/O output	Dedicated Output 4 points, General output 16 points						
	SAFETY	Emergency stop input (Normal close contact point input), service mode input							
	Brake output	Relay contact					-		
	Origin sensor input	Connectable to DC 24V normally-closed contact sensor							
	External communications	RS-232C: 1CH (For communication with HPB / HPB-D or PC)							
	Analog input/output	Input 1ch (0 to +10V) Output 2ch (0 to +10V)							
	Options	Slots	Type	1					
			Type	NPN/PNP: Dedicated input 8 points, Dedicated Output 4 points, General input 16 points, General output 16 points					
				CC-Link: Dedicated input 16 points, Dedicated Output 16 points, General input 32 points, General output 32 points					
DeviceNet: Dedicated input 16 points, Dedicated Output 16 points, General input 32 points, General output 32 points									
PROFIBUS: Dedicated input 16 points, Dedicated Output 16 points, General input 32 points, General output 32 points									
Options	Programming box	HPB, HPB-D (with enable switch)							
	Support software for PC	POPCOM							
General specifications	Operating temperature	0°C to 40°C							
	Storage temperature	-10°C to 65°C							
	Operating humidity	35% to 85%RH (non-condensing)							
	Absolute backup battery	Lithium metallic battery					-		
	Absolute data backup period	1 year (in state with no power applied)					-		
Noise immunity	IEC61000-4-4 Level 3								

## [NPN, PNP type] Input/Output list

Terminal number	Signal name	Function
1	DI.+COM	Input supply+common
2	SERVO	Return to servo on
3	INC-PT	Relative point transfer
4	ABS-PT	Absolute point transfer
5	STEP-R	Step run
6	DI 0	General input 0
7	DI 1	General input 1
8	DI 2	General input 2
9	DI 3	General input 3
10	DI 4	General input 4
11	DI 5	General input 5
12	DI 6	General input 6
13	DI 7	General input 7
14	DO.+COM	Output supply+common
15	DO.+COM	Output supply+common
16	END	Execution result (Execution complete)
17	BUSY	Executing the command
18	DO 0	General output 0
19	DO 1	General output 1
20	DO 2	General output 2
21	DO 3	General output 3
22	DO 4	General output 4
23	DO 5	General output 5
24	DO 6	General output 6
25	DO 7	General output 7
26	DI.-COM	Input supply-common
27	AUTO-R	Auto run
28	RESET	Reset
29	ORG-S	Return to the origin
30	ALMRST	Alarm reset
31	DI 8	General input 8
32	DI 9	General input 9
33	DI 10	General input 10
34	DI 11	General input 11
35	DI 12	General input 12
36	DI 13	General input 13
37	DI 14	General input 14
38	DI 15	General input 15
39	DO.-COM	Output supply-common
40	DO.-COM	Output supply-common
41	READY	Available to operate (Ready for operation)
42	UTL	Utility output
43	DO 8	General output 8
44	DO 9	General output 9
45	DO 10	General output 10
46	DO 11	General output 11
47	DO 12	General output 12
48	DO 13	General output 13
49	DO 14	General output 14
50	DO 15	General output 15

## SAFETY connector signals

Terminal number	Signal name	Meaning
1	DI.COM	Input supply common
2	LOCK	Interlock
3	SVCE	SERVICE mode
4	DO.COM	Output supply common
5	MPRDY	Main power ready
6	NC	NC
7	NC	NC
8	NC	NC
9	NC	NC
10	NC	NC
11	EMG1	Emergency stop 1
12	EMG2	Emergency stop 2
13	NC	NC
14	NC	NC

## NPN type input/output circuit

### Input circuit

- Form : DC input (positive common type)  
Photo coupler insulation type
- Input power supply : 5mA/point
- Answering time : 30ms or less

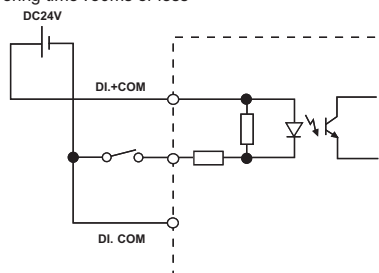

### Output circuit

- Form : NPN open collector output (negative common type)  
Photo coupler insulation type
- Load : 50mA/point
- Answering time : 1ms or less

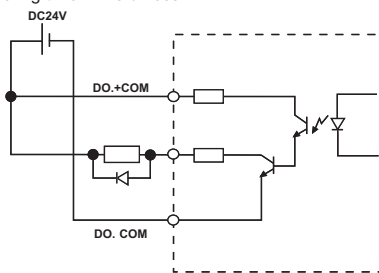

## PNP type input/output circuit

### Input circuit

- Form : DC input (negative common type)  
Photo coupler insulation type
- Input power supply : 5mA/point
- Answering time : 30ms or less

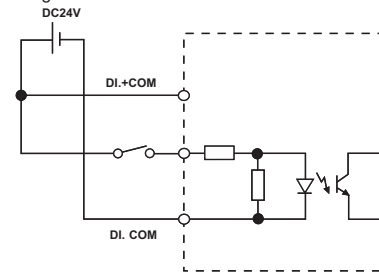

### Output circuit

- Form : PNP open collector output (positive common type)  
Photo coupler insulation type
- Load : 50mA/point
- Answering time : 1ms or less

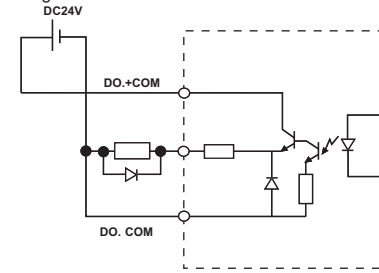

**Robot Language Table**

Command	Description
MOVA	Moves to a point data position.
MOVI	Moves from current position by amount of point data.
MOVF	Moves until a specified DI input is received.
JMP	Jumps to a specified label in the specified program.
JMPF	Jumps to a specified label in a specified program according to the input condition.
JMPB	Jumps to a specified label in a specified program when general-purpose input or memory input is in the specified state.
L	Defines the jump destination for a JMP or JMPF statement.
CALL	Runs another program.
DO	Turns general-purpose output or memory output on or off.
WAIT	Waits until general-purpose input or memory input is in the specified state.
TIMR	Waits the specified amount of time before advancing to the next step.
P	Defines point variable.
P+	Adds 1 to point variable.
P-	Subtracts 1 from point variable.
SRVO	Turns servo on or off.
STOP	Temporarily stops program execution.
ORGN	Performs return-to-origin.
TON	Runs a specified task.
TOFF	Stops a specified task.
JMPP	Jumps to a specified label when the axis position condition meets the specified conditions.
MAT	Defines a matrix.
MSEL	Specifies a matrix to move.
MOVMM	Moves to a specified pallet work position on matrix.
JMPC	Jumps to a specified label when the counter array variable C equals the specified value.
JMPD	Jumps to a specified label when the counter variable D equals the specified value.
CSEL	Specifies an array element for counter array variable C.
C	Defines counter array variable C.
C+	Adds a specified value to counter array variable C.
C-	Subtracts a specified value from counter array variable C.
D	Defines counter variable D.
D+	Adds a specified value to counter variable D.
D-	Subtracts a specified value from counter variable D.
SHFT	Shifts the coordinate position by amount of specified point data.
IN	Stores bit information on specified general-purpose input or memory input into counter variable D.
OUT	Outputs the value of counter variable D to specified general-purpose output or memory output.
LET	Shifts the coordinate position by amount of specified point data.

APPLICATION

TRANSERVO  
Compact  
single-axis robots

FLIP-X  
Single-axis robots

PHASER  
Linear motor  
single-axis robots

XY-X  
Cartesian  
robots

YK-XG  
SCARA  
robots

YP-X  
Pick & place  
robots

CLEAN

CONTROLLER

INFORMATION

Robot  
positioner

Pulse string  
driver

Robot  
controller

IVY

Option

## Accessories and part options

### Standard accessories

#### Power connector + wiring connection lever



Model	KAS-M5382-00
-------	--------------

Note. Jointly used by RCX221 / 222, RCX240.

#### Safety connector



Connector plug model	KBG-M4424-00
Connector cover model	KBG-M4425-00

#### HPB dummy connector

Attach this to the HPB connector during operation with the programming box HPB removed.

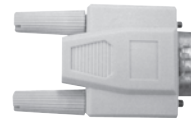

Model	KBG-M5163-00
-------	--------------

#### NPN / PNP connector

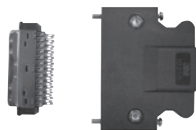

Connector plug model	KBH-M4424-00
Connector cover model	KBH-M4425-00

Note. Jointly used by RCX221 / 222.

#### L type stay

Use to install the controller.



Model	KBG-M410H-00
-------	--------------

#### Battery case

This is the absolute battery holder.



Model	KBG-M5395-00
-------	--------------

#### Absolute battery (only for SR1-X)

Battery for absolute data back-up.

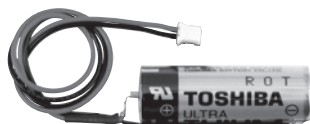

#### Absolute battery basic specifications

Item	Absolute battery
Model	KAS-M53G0-10
Battery type	Lithium metallic battery
Battery capacity	3.6V/2,700mAh
Data holding time	1 year <sup>Note1</sup>
Dimensions	φ17 × L53mm
Weight <sup>Note2</sup>	22g

Note1. When using 2 batteries. Note2. Weight of battery itself.  
Note. Jointly used by RCX222, RCX240.

### Options

#### Cable for monitor I/O

Cable to connect I/O connector of SR1 monitor. The cable is 1.5m long with its end cut and left as it is. Required when using analog input / output and feedback pulse output.



Model	KBG-M4421-00
-------	--------------

#### PC support software POPCOM

POPCOM is a simple to use application software that makes tasks such as robot operation, writing-editing programs, and point teaching easy to visually understand.



POPCOM software model	KR4-M4966-00
-----------------------	--------------

Note. Use POPCOM with Version 1.13.0 or later when using SR1-P / SR1-X.



Data cable (9Pin-9Pin) 5m	KAS-M538F-10
---------------------------	--------------

Note. Data cable jointly used for POPCOM, VIP, VIP\*.

#### Programming box HPB / HPB-D

This device can perform all operations such as manual robot operation, program entry and edit, teaching and parameter settings.



	HPB	HPB-D
Model	KBB-M5110-01	KBB-M5110-21
Enable switch	-	3-position
CE marking	Not supported	Applicable

#### Environment

OS	Microsoft Windows 3.1/95/98/Me/NT/2000/XP Note. The 64 bit version is not subject to the operation warranty.
CPU	Exceeding the environment recommended by the OS being used
Memory	Exceeding the environment recommended by the OS being used
Hard disk	Vacant capacity of more than 4MB in the installation destination drive
Disk operation	CD-ROM drive
Applicable controllers	ERCD / ERCX / SR1-P / SR1-X / SRCP30 / DRCX

Note. Windows is the registered trademark of US Microsoft Corporation in U.S.A. and other countries.

**P.391**

**P.393**

Note. Use the converter cable if changing to the SR1-X, SR1-P from a system using SRCX, SRCP. (See P.427).